

FENIX

G42

Rev. 0.2

August 2024



FENIX G42 is an high-competition, high-quality, 1/10-scale model car intended for persons aged 16 years and older with previous experience building and operating RC model racing cars. This is not a toy; it is a precision racing model. This model racing car is not intended for use by beginners, inexperienced customers, or inexperienced racers or by children without direct supervision of a responsible, knowledgeable adult.

Before building and operating your FENIX G42, YOU MUST read through all of the operating instructions and instruction manual and fully understand them to get the maximum enjoyment and prevent unnecessary damage. Read carefully and fully understand the instructions before beginning assembly.

Contents of the box may differ from pictures. In line with our policy of continuous product development, the exact specifications of the kit may vary without prior notice.

Take appropriate safety precautions prior to operating this model. You are responsible for this model's assembly and safe operation! Please read the instruction manual before building and operating this model and follow all safety precautions

IMPORTANT NOTES – GENERAL

- This product is not suitable for children under 16 years of age without the direct supervision of a responsible and knowledgeable adult.
 - Carefully read all manufacturers warnings and cautions for any parts used in the construction and use of your model.
 - Assemble this kit only in places away from the reach of very small children.
 - First-time builders and users should seek advice from people who have building experience in order to assemble the model correctly and to allow the model to reach its performance potential.
 - Exercise care when using tools and sharp instruments.
 - Take care when building, as some parts may have sharp edges.
 - Keep small parts out of reach of small children. Children must not be allowed to put any parts in their mouth, or pull vinyl bag over their head.
 - Read and follow instructions supplied with paints and/or cement, if used (not included in kit).
 - Immediately after using your model, do NOT touch equipment on the model such as the motor and speed controller, because they generate high temperatures. You may seriously burn yourself seriously touching them.
 - Follow the operating instructions for the radio equipment at all times.
 - Do not put fingers or any objects inside rotating and moving parts, as this may cause damage or serious injury as your finger, hair, clothes, etc. may get caught.
 - Be sure that your operating frequency is clear before turning on or running your model, and never share the same frequency with somebody else at the same time. Ensure that others are aware of the operating frequency you are using and when you are using it.
 - Use a transmitter designed for ground use with RC cars. Make sure that no one else is using the same frequency as yours in your operating area. Using the same frequency at the same time, whether it is driving, flying or sailing, can cause loss of control of the RC model, resulting in a serious accident.
 - Always turn on your transmitter before you turn on the receiver in the car. Always turn off the receiver before turning your transmitter off.
 - Keep the wheels of the model off the ground when checking the operation of the radio equipment.
 - Disconnect the battery pack before storing your model.
 - When learning to operate your model, go to an area that has no obstacles that can damage your model if your model suffers a collision.
 - Remove any sand, mud, dirt, grass or water before putting your model away.
 - If the model behaves strangely, immediately stop the model, check and clear the problem.
 - To prevent any serious personal injury and/or damage to property, be responsible when operating all remote controlled models.
 - The model car is not intended for use on public places and roads or areas where its operation can conflict with or disrupt pedestrian or vehicular traffic.
 - Because the model car is controlled by radio, it is subject to radio interference from many sources that are beyond your control. Since radio interference can cause momentary loss of control, always allow a safety margin in all directions around the model in order to prevent collisions.
 - Do not use your model:
 - Near real cars, animals, or people that are unaware that an RC car is being driven.
 - In places where children and people gather
 - In residential districts and parks
 - In limited indoor spaces
 - In the street
 - in wet conditions unless you use special precautions
 - In areas where loud noises can disturb others, such as hospitals and residential areas.
 - At night or anytime your line of sight to the model may be obstructed or impaired in any way.
- To prevent any serious personal injury and/or damage to property, please be responsible when operating all remote controlled models. Failure to follow these instructions will be considered as abuse and/or neglect.
- We have made every effort to make these instructions as easy to understand as possible. However, if you have any difficulties, problems, or questions, please do not hesitate to contact the Fenix support team at racing@fenixwaterjet.com . Also, please visit our Web site at www.Fenix-racing.com or www.fenixracingshop.com or <https://www.facebook.com/FenixRacing.it/> the latest updates, set-up information, option parts, and many other goodies. We pride ourselves on taking excellent care of our customers.

Just a quick note.... Read the manual "before" and not after....

If you're super lazy



Scan the QR code, there will be a photo guide for the assembly.

It does not substitute the manual, it's intended to be a visual support



Thanks to Marco for the idea...

Carbon Nut assembly

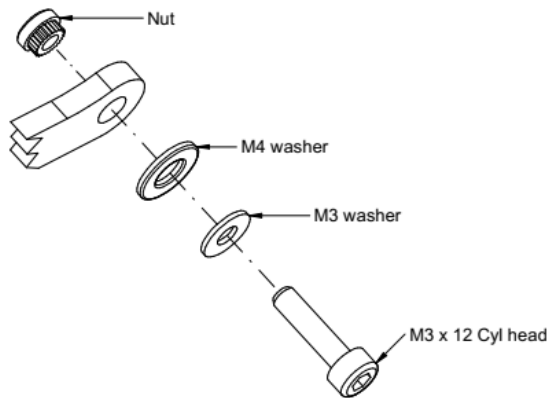

----- **Read me first!!!** -----

Fenix G42 use this kind of special nut in several places. Just take your time and the result will be great.

To insert the Nut in the carbon fibre you have to follow this easy procedure.

Slide the M3 and M4 washer over the M3 x 12 Socket Head Screw.

Insert the screw in the carbon part and tight by hand the special nut.

Once the nut hit the carbon fibre it will start to secure itself into the CF.

Tight it slowly (very slowly) until it stop.

Don't overtight it – is completely unnecessary

Tip 1:

You might want to slightly chamfer the Top face with your body reamer. Just enough to remove the sharp edge

Tip 2:

When the nut hit the carbon fibre, before insert it fully, you can add a tiny drop of thin slow cure CA glue. *Very tiny....*

Tip 3:

Don't use electric tools to drive the screw, most likely you'll end damaging the carbon fibre....

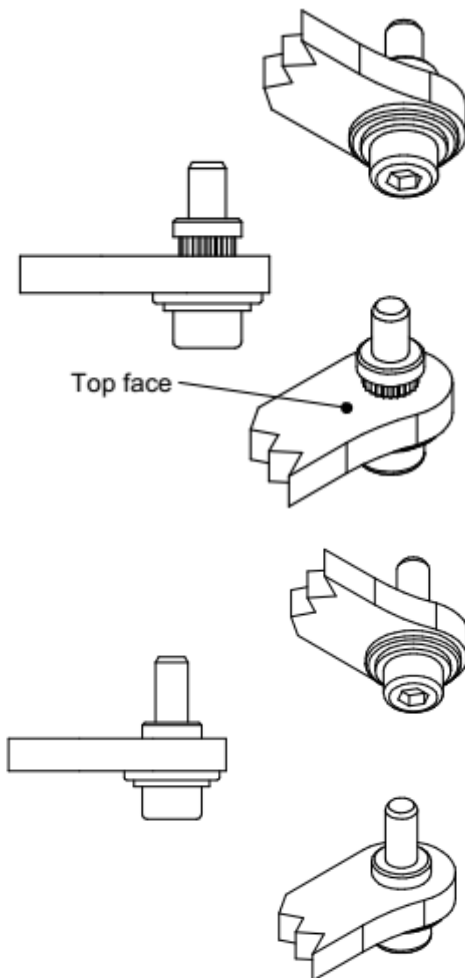

\

Before start...

Grab a cup of coffee, tea or whatever you like to drink.

Put away the tools and read the manual...



Bag A Mechanical parts

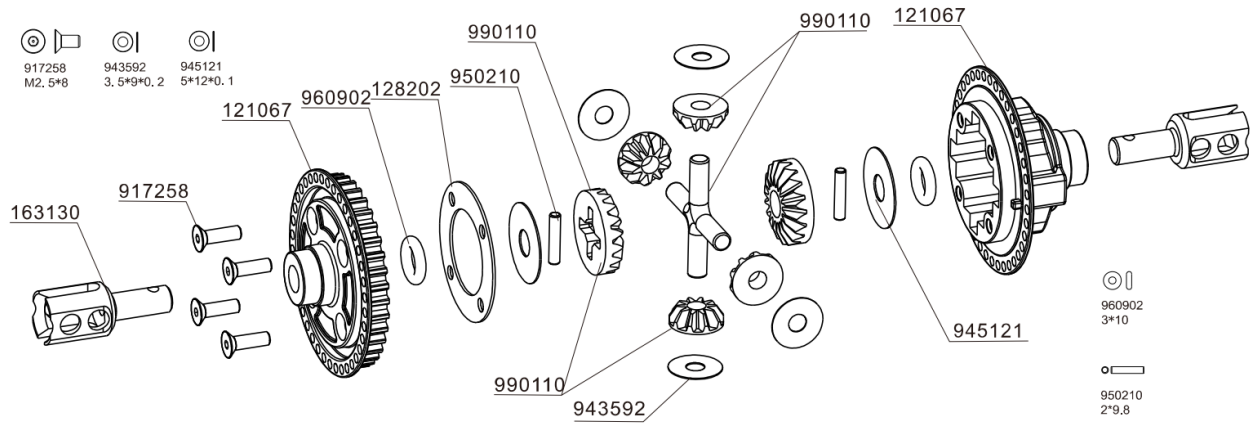

943592 WASHER S 3, 5x9x0, 2
 945121 WASHER S 5x12x0, 1
 163130 UNIVERSAL CVD DRIVE SHAFT-SPRING STEEL 3.1 S2

990110 PLANETARY GEAR SET-PLASTIC
 121067 COMPOSITE GEAR DIFF. CASE & COVER
 128202 DIFF GASKET

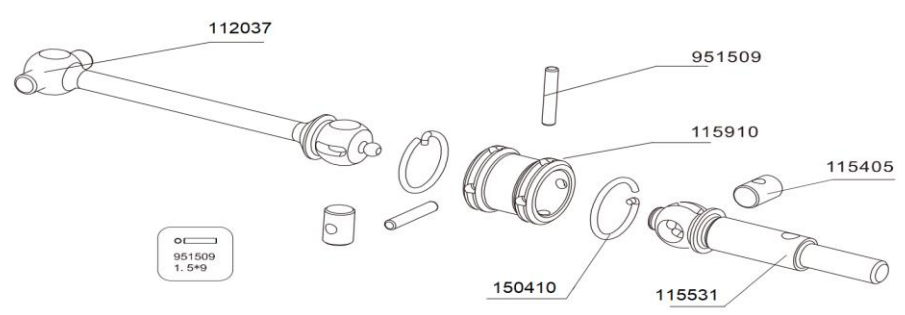
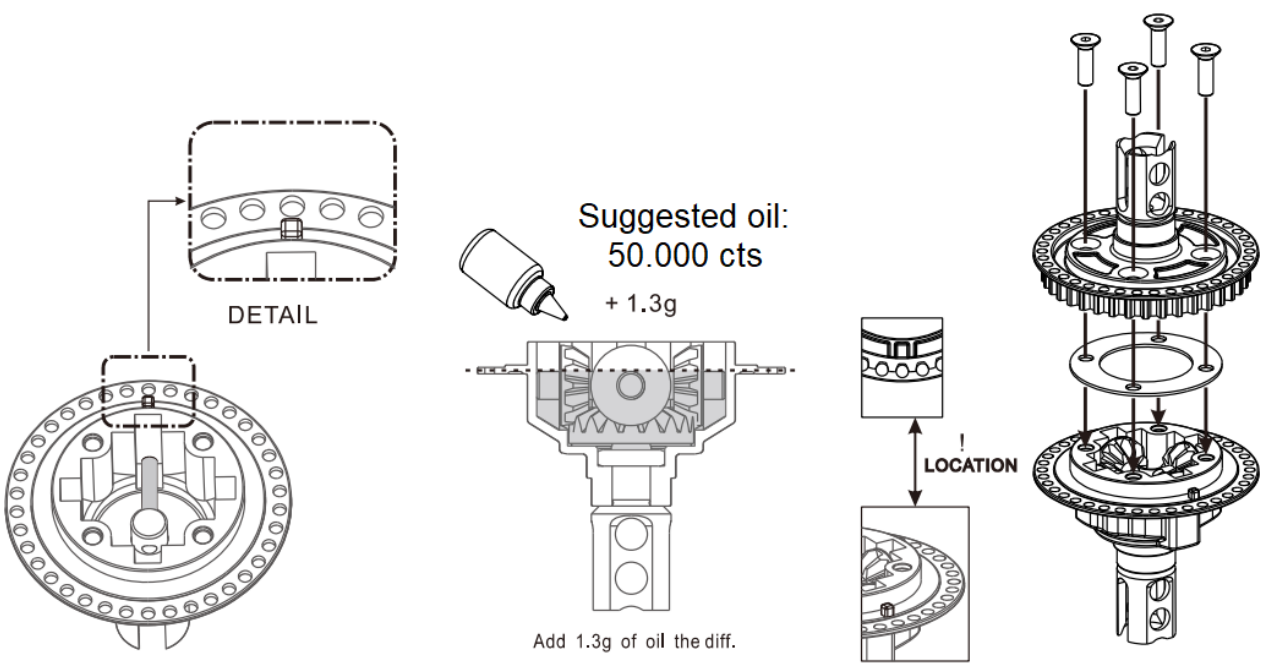

Bag B

Front + Rear Arms assembly

Note:

Some of the plastic components are MJF 3d printed. Take a bit of care when thread them.

G42 arms are “double mirrored”.

This is done to keep your inventory of spare to the minimum.

Front Left Arm will serve also as Rear Right Arm and so on.

This will also ensure the symmetry of the suspension.

Insert the M3 carbon nut into the arms, as explained before.

Glue the sphere holders

Note: holes for the sphere holders are a bit on the tight side, we recommend to check the fitting **before**. Use some sandpaper to enlarge the hole if needed.

Use 3 M3 x 6 to fix the Joint holder

Prepare 2 double couples as shown.

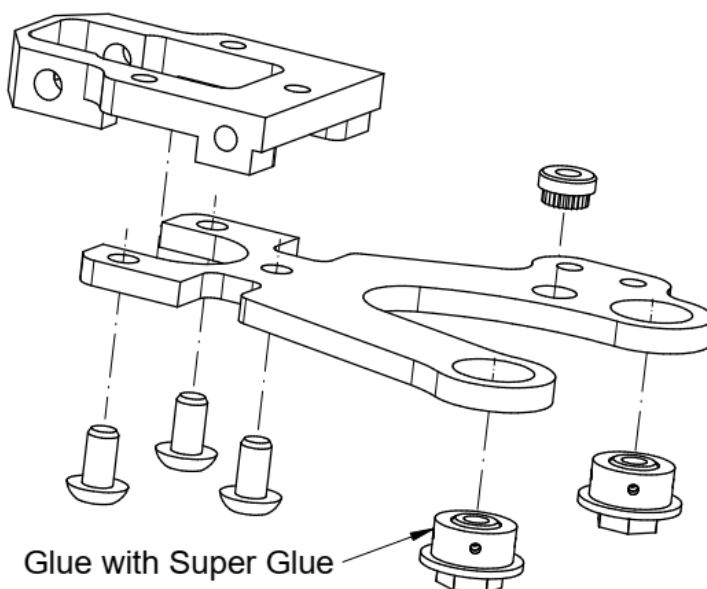
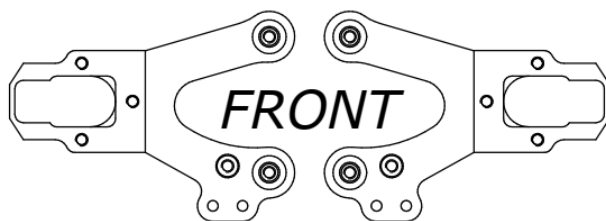
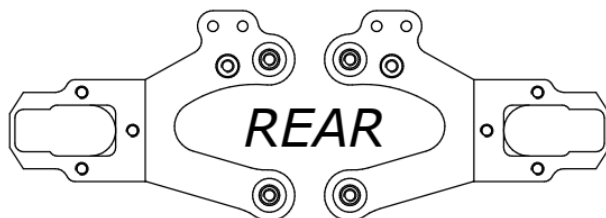
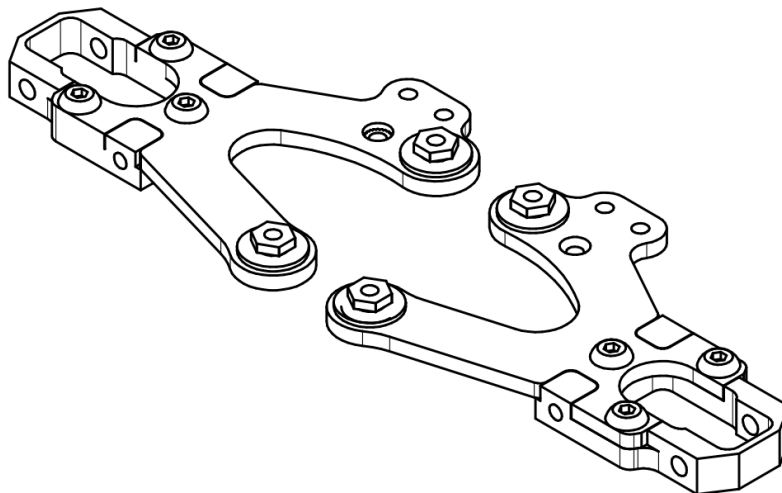

FENIX G42

Also steering hubs are mirrored, from front and rear.

So, prepare 2 couples, insert 2 bearings 10x5x4 and insert a male stud as show. Insert an 8mm ball stud on the top hole

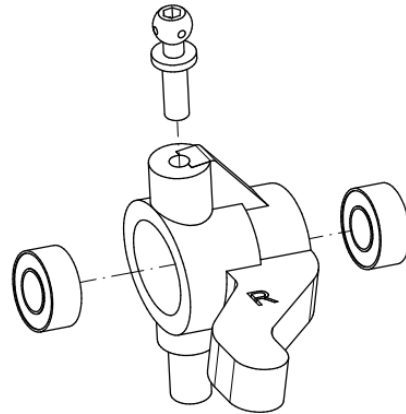

REAR hub blocks are at ZERO degree caster, so Left and Right are mirrored.

FRONT hub blocks are at **FOUR** degree caster, so make Left and Right.

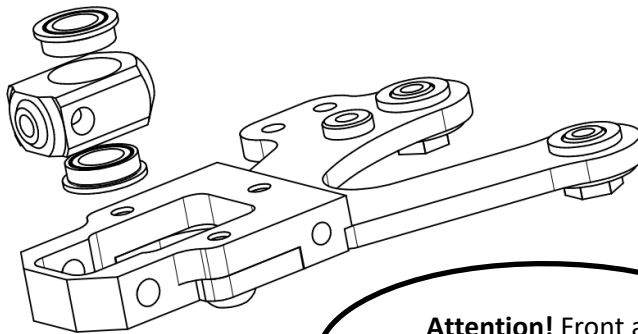

Attention! Front and Rear are different!

Insert 2 8*5*2.5 flanged bearing as shown, and insert the assembly into the joint holder

Insert the hinge pin as shown. Make a flat spot in the centre of the hinge ping.

Note: You know already you should wear protective stuffs... *Isn't?*

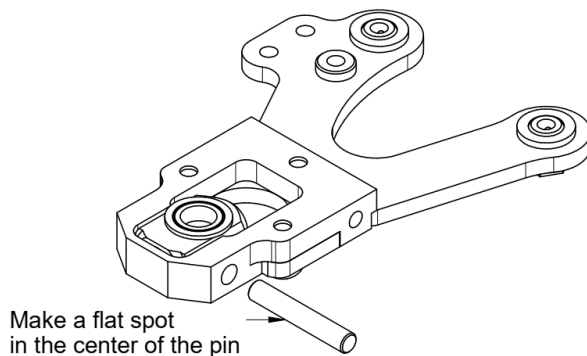

Hold the hinge pin in position using an M3x3 grub screw

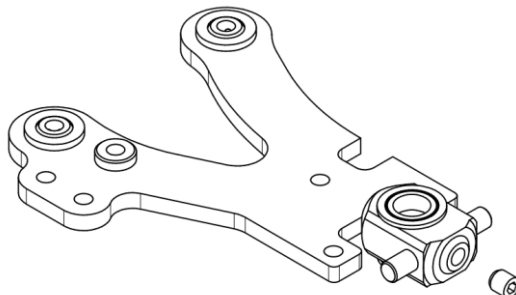

FENIX G42

Insert the steering hub as shown and fix it with an M3x12 button screw

Until this point, the assembly procedure for the arms, is equal for front and rear

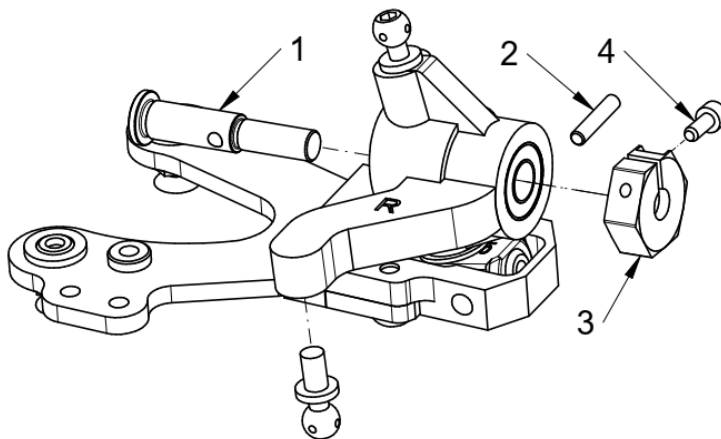
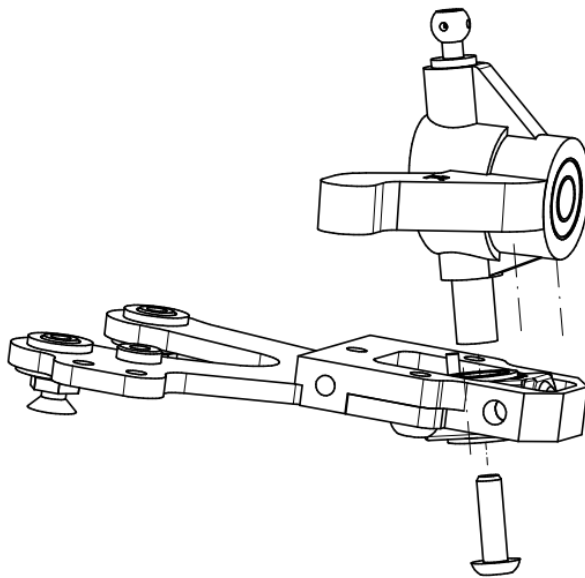

Rear Arm:
Insert the axle into the bearing, then the 9mm pin, then the Hex driver, and close it in position with the M2x5 screw

Note:
Steering male stud and rear toe male stud are 4.8mm diameter.
Camber are 4.9mm

Front arm:

Exactly the same as rear, just use the DCV instead of the plain axle.

Also, the steering male stud need to be inserted from the top.

Note: camber stud is the special "double sphere" one.

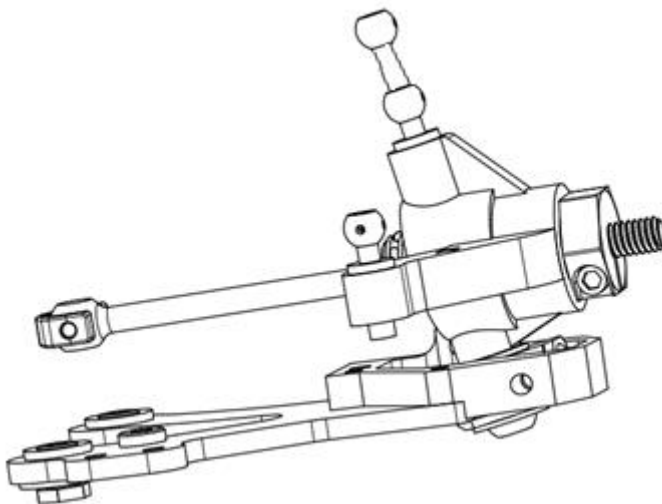

Bag C

Transmission

Fix the 2 front bulkheads to the chassis using 4 screws M3x6 countersunk. Be sure that those are parallel between them before tight.

Insert 2 x M3x16 countersunk into the motor bulkhead, then slide the spacer (5+1mm) and screw it in the front bulkhead. Insert 2 screws M3x6 countersunk. Just put all the 4 screw "close" not tight.

Insert 2 x M3x10 countersunk into the bearing shoulder, then screw it in the front bulkhead. Just put all the 2 screw "close" not tight.

Slide the belt over the differential and insert it into the bulkheads.

While you're at, insert the bearings 5x10x4 into the Motor Bulkhead and the Bearing Shoulder.

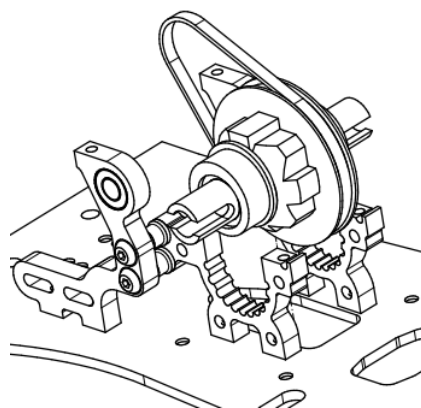
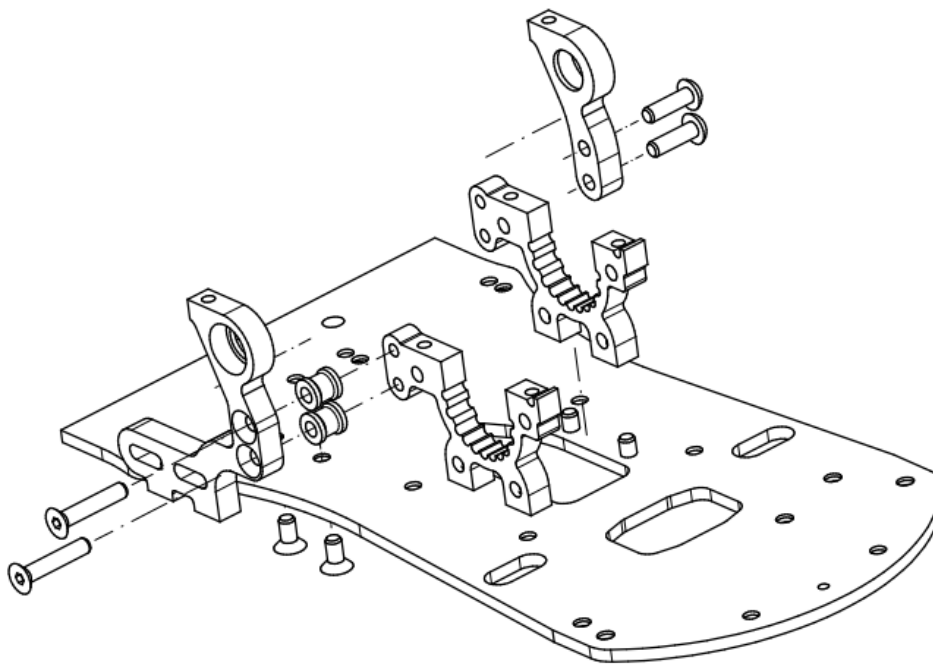

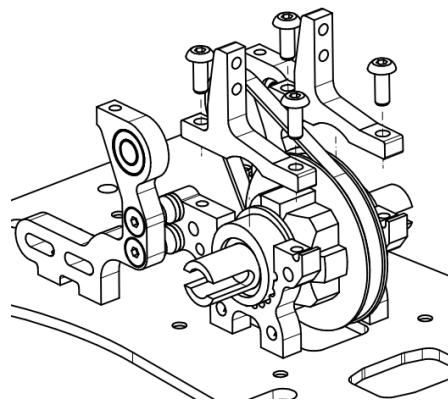

Close the assembly with the bearing holders using 4 by M3x8 button screws

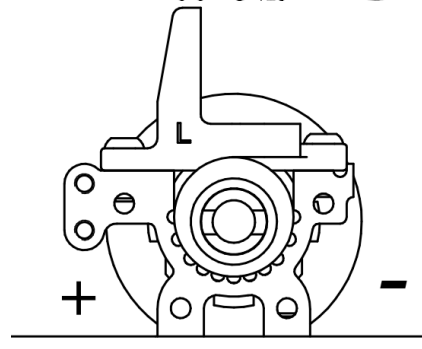

Belt tension adjustment

BTW, the Internal Ratio is 2.00

Pulley is 19, gear 38

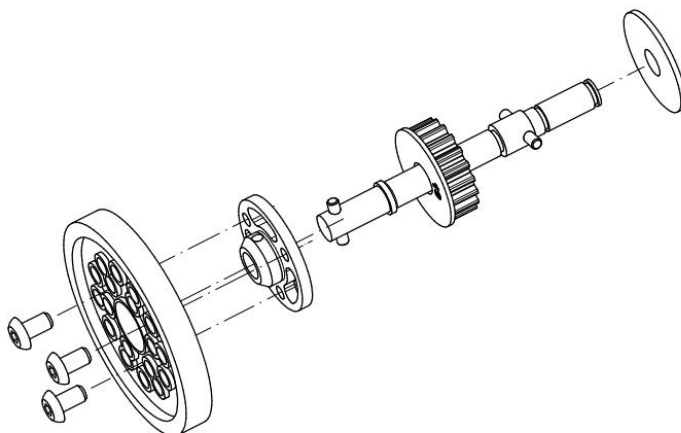

Pulley axle components

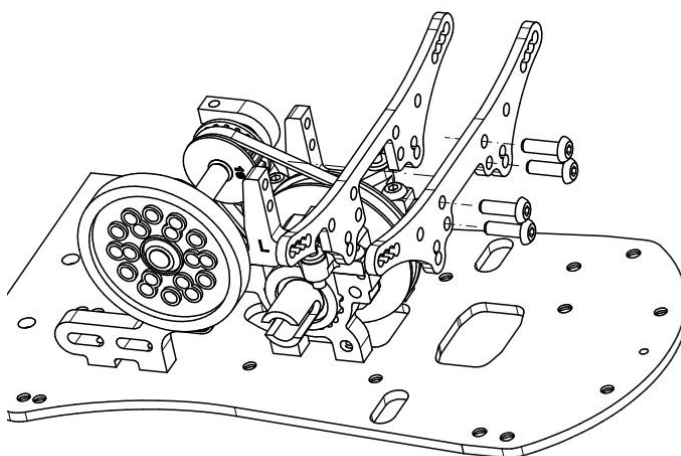

Now you install the shock holders, using 4 by M3 x 10mm button screws.

Please note that the shock holder are having different shape, in order to provide enough clearance for the spur.



A is closer to the mounts

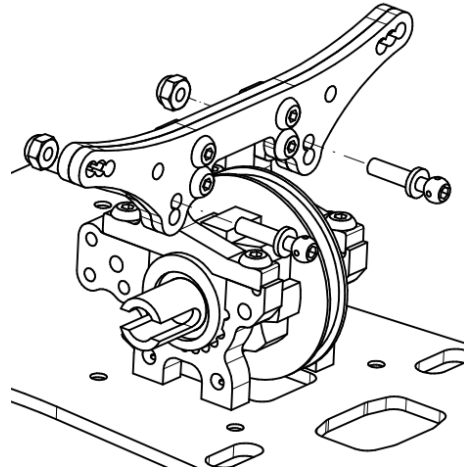

Insert 2 x 10mm male stud into the shock holders.

Bag D

Steering ass.y

G42 is designed to use Low profile and super Low profile servo only.

G42 has been developed using servos, with the aluminium case, in order to have a bit more weight in the front of the car.

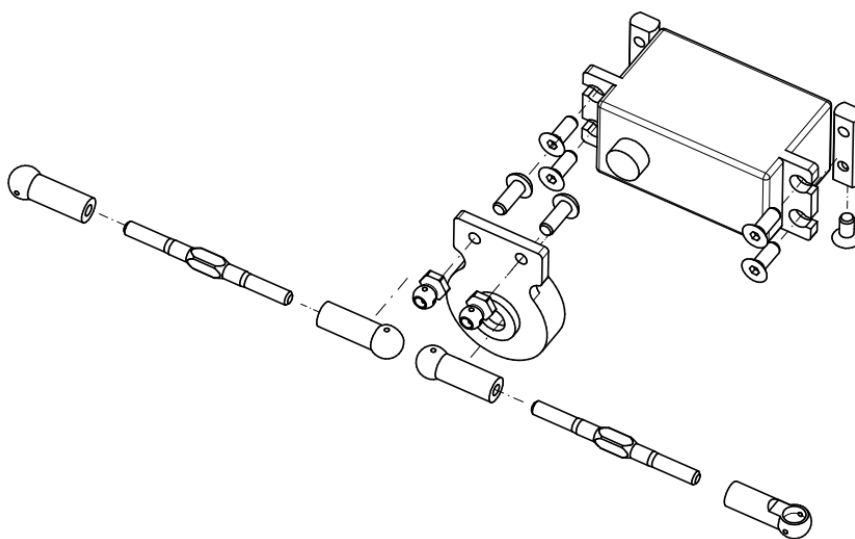
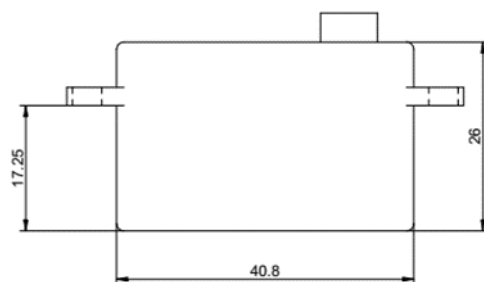

Tip!
Install the servo already radio centered, it will be easier later.

Use the 4 x M3x8 countersunk screw to fix the FX022 servo mount.
Servo will be fixed to the chassis using 2 x M3x5 countersunk screw.

FENIX G42

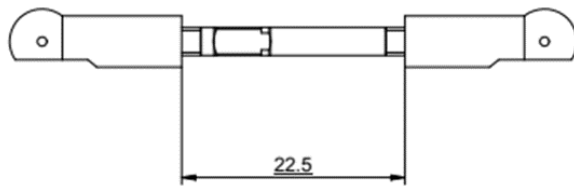

Make 2 tie-rod with 22.5mm

Ball male stud should be used on the steering hub.

G42011 body holder should not touch the servo, a minimal clearance is needed.

Install 1mm spacer under the FX0053 20mm post when you fix them to the chassis.

Use 2 M3x8 countersunk to fix the 20mm posts to the chassis.

Fix the G42011 to the 20mm posts using 2 x M3x6mm button screws.

Fix the body post using 2 x M3x6mm button screws.

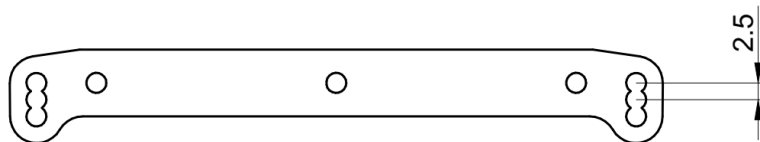
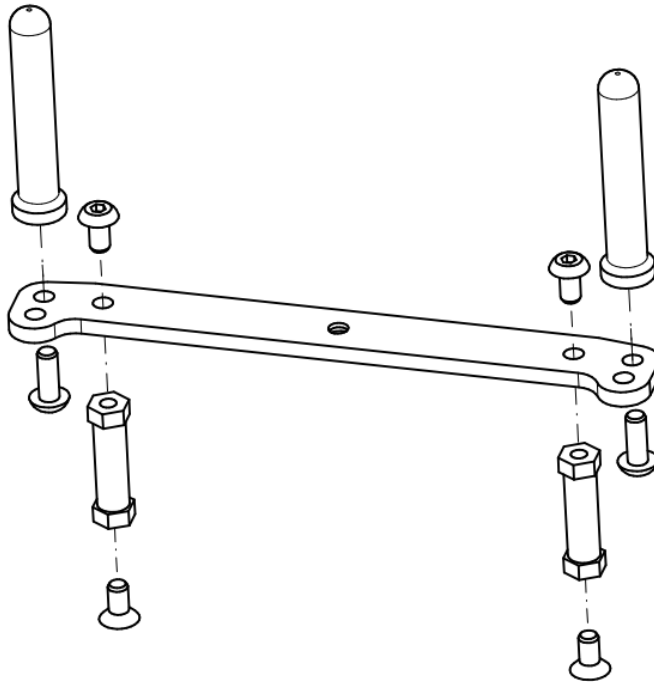

G42011 allow to change the position of the body by 2.5mm, so you can just cut the body as designed and if you need some extra front downforce, just move the body post 1 or 2 "clicks" forward.

Isn't the coolest stuff since the invention of the Milkshake?

Already here?
Excellent! How about a cup of coffee now?
Tea and biscuits? A can of your favourite soda?



While you rest a bit...
you can enjoy your snack, you read again the manual... . 😊

Note:

Some of the plastic components are MJF 3d printed.
Take a bit of care when thread them.

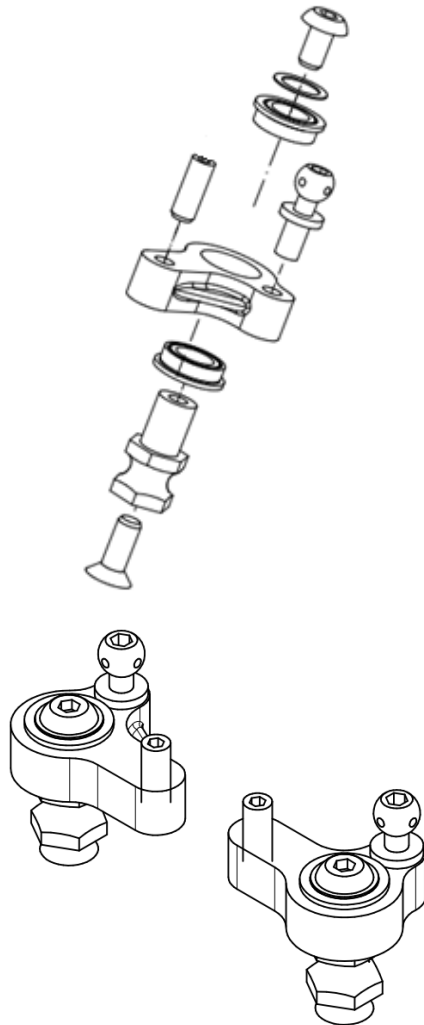

Bag E

Shocks and chassis parts

Assembly the 2 rear suspensions rockers.

Note:

you might have to enlarge the 8mm hole with some sandpaper. Do not exceed.

If necessary, use the provided shims to remove the vertical play to the minimum.

M3x8 countersunk screw, will be used to fix the rockers to the chassis

Prepare 2 mirror groups

Movement of the rockers should be free and fluid

FENIX G42

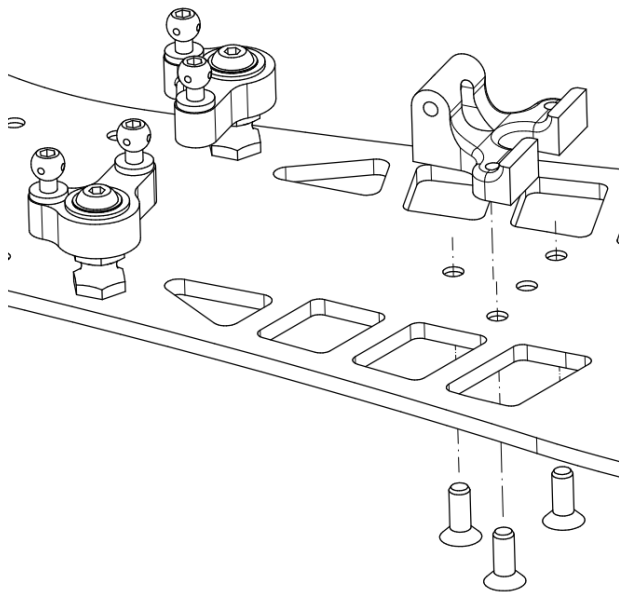

Fix the rocker as shown.

Fix the shock holder as shown, using 2 x M3x8 countersunk screws

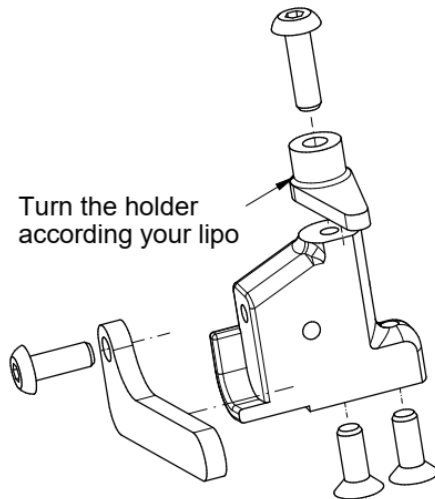

Turn the holder according your lipo

Battery holder is designed to work with both, LCG and normal shorty lipo.

Just turn the holder according the battery of your choice. Top screw is M3x12
Make 2 mirror groups.

Fix each battery holder using 2 M3x8 countersunk screws

Note:
We've used the most common lipo in the market, but lipo cases are not standardized.

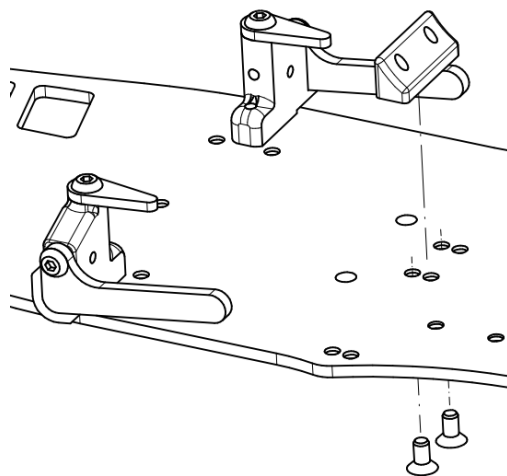

Now fix the central battery holder using 2 M3x6 screws

Note: the flat face should match the battery

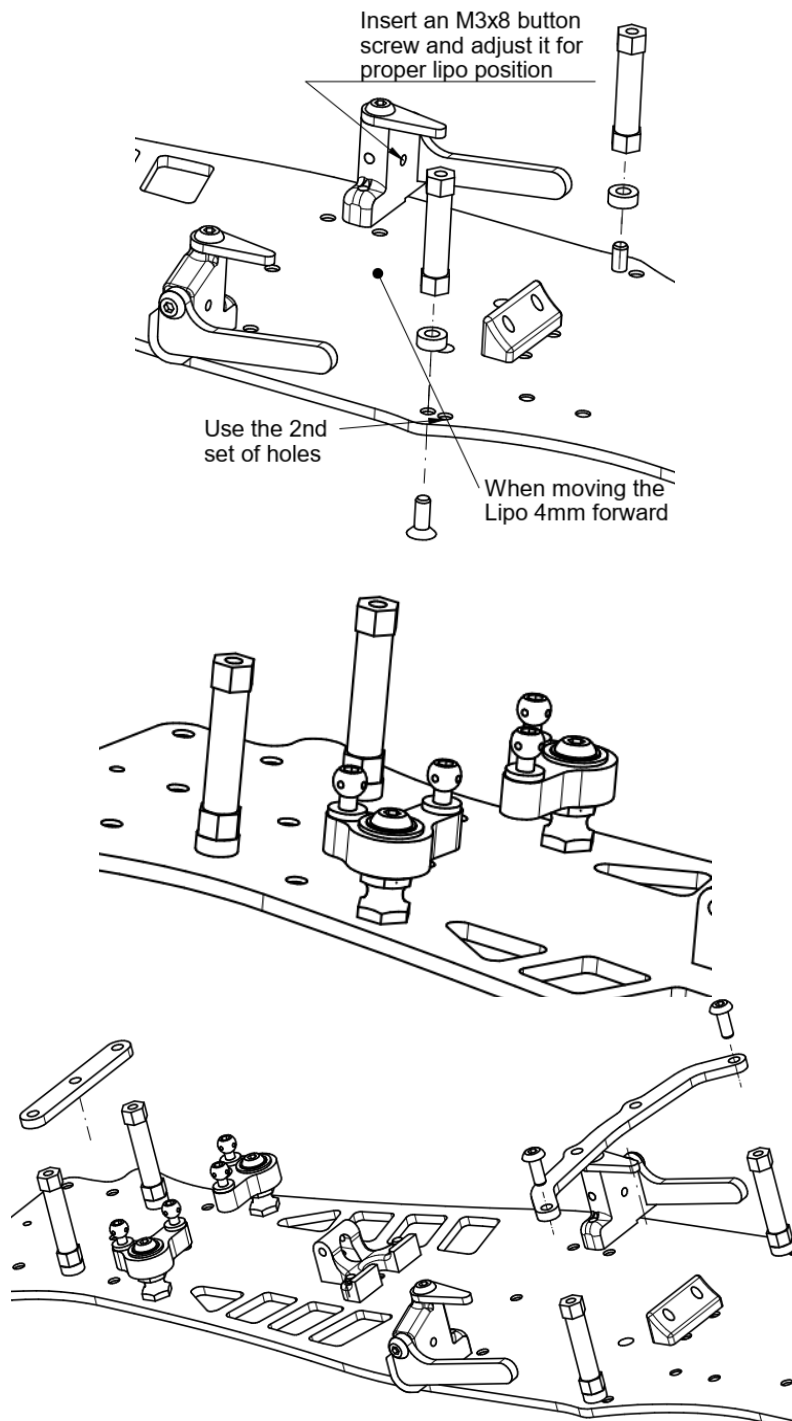

Using 2 x M3x 8 countersunk screw, fix 2 x 26mm post to chassis.

Insert a 2.5mm shim between the posts and the chassis

Note: when moving the Lipo 4mm forward.

Use the most forward holes. Insert an M3x8 button screw in the battery holder and adjust it properly

Do the same for the rear posts

On the front post, fix the G42006 bridge, using 2 x M3x 8 button screws.

On the rear posts, you will use the plate G42007.

You'll fix in position in the next step...

FENIX G42

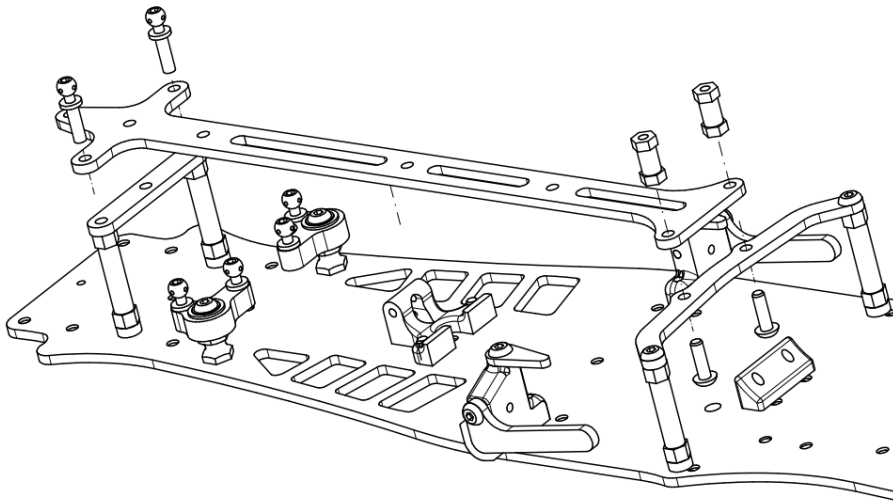

Fix the G42005 Upper Deck using 2 male stud 10mm at the rear and 2 x M3x10 at the front.

Fix in the position 2 x 12mm posts.

Note: fan holder will join this area with the motor block.

Can be omitted if you want more torsion in the area

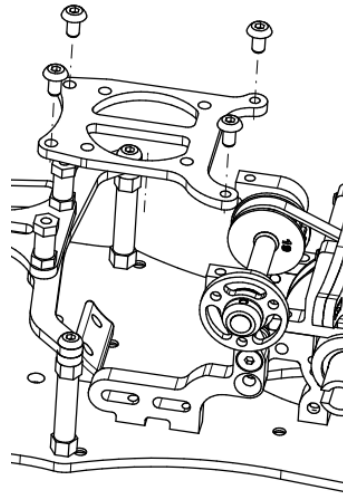

Fan holder G42009 can be fixed with 4 x M3x6 button screw.

If you use a low profile fan, it can be installed between the fan and the motor.

Thicker fan might need to add some shims between the holder and the other components. Check for the length of the screw!

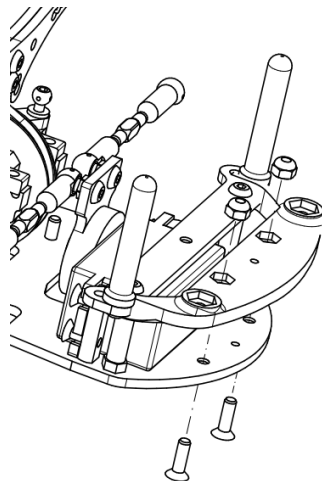

Add the front bumper to the chassis, using 2 x M3x10 countersunk screws.

Use 2 M3 Nylock

FENIX G42

At the rear, you can install FX022, to the chassis using 2 x M3x5 countersunk screws

Then fix the body holder using 2 x M3x8 buttons screws

Then using 2 x M3x10 buttons screws, you can fix the female studs for the rear toe-in

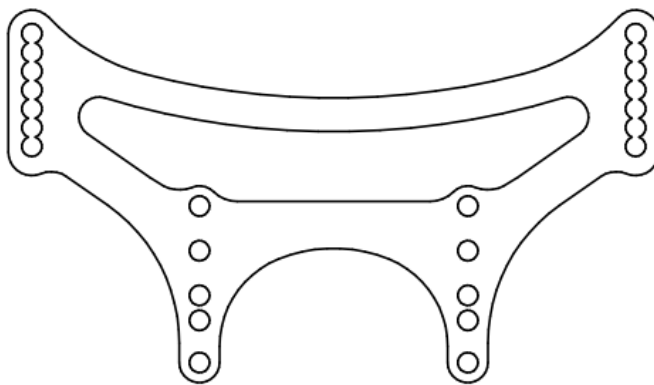
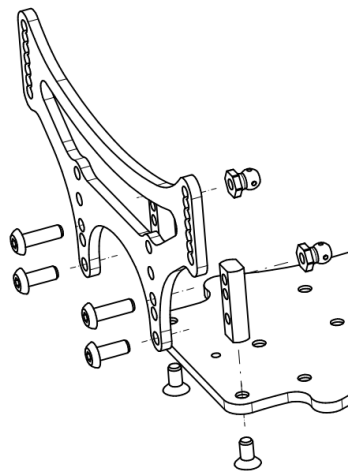

There are several option location to set the rear Toe-In location, in order to have several bump steer setting.

Please note that the rear body holder is plenty of options to fix the rear body posts.

Use 2 x M3x8 button screws, to fix the body posts

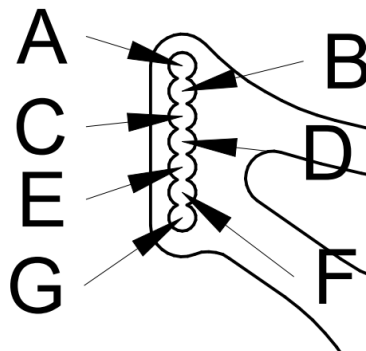

Arm assembly

Using 4 x M3x8
countersunk screws,
you can fix the front
arms now

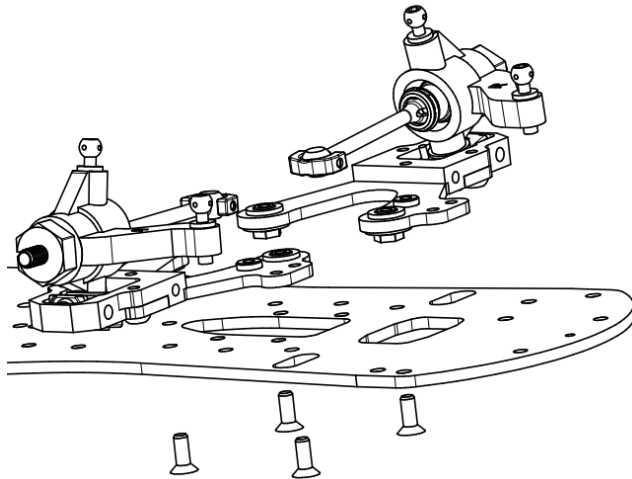

Using 4 x M3x8
countersunk screws,
you can fix the rear
arms

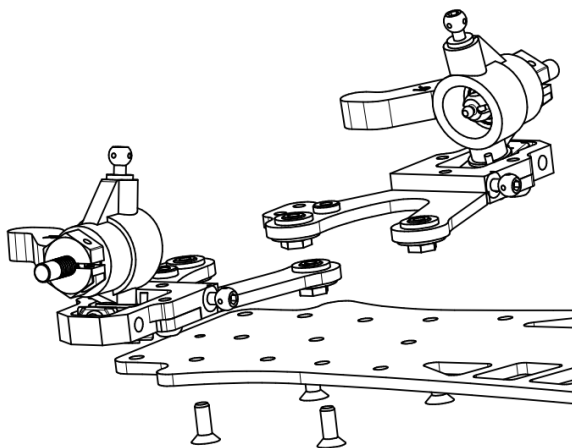

Bag F

Shocks and tie-rod assembly

Make 4 shocks, suggest oil is 600

Suggest front springs are yellow ones

Suggest rear springs are silver ones

But any 19-20mm spring will do the game

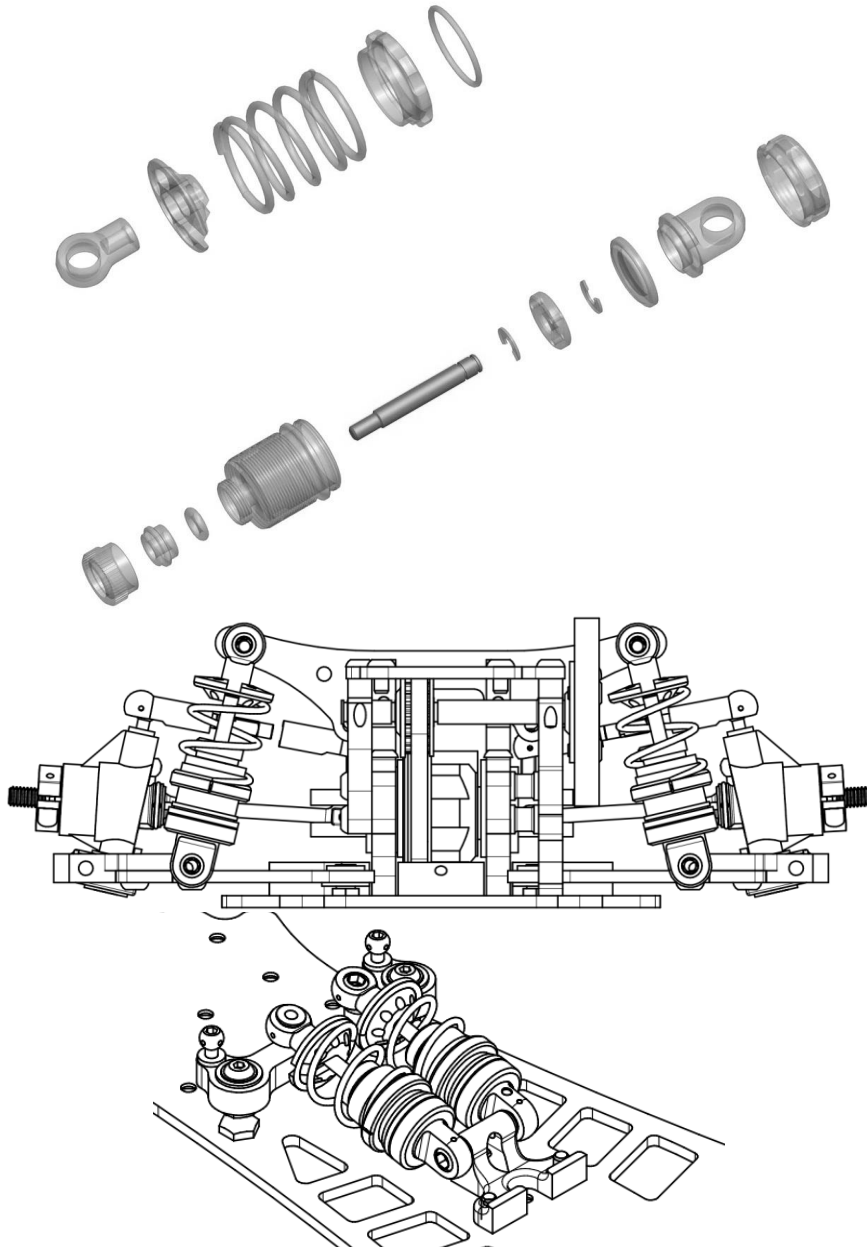

You can install the front shocks now.

Yes... upside down...

Rear ones.

Let's assembly some tie rods...

Take care that the front ones are using the "open" ball joint. The open ones are to be used on the steering upright

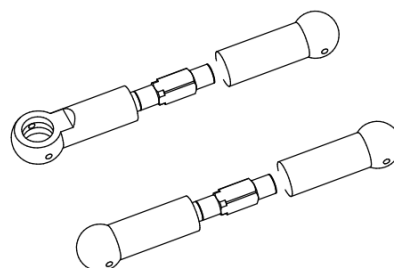

Camber tie rods...

Make 2 double sets:

Rear and Front ones

Use 15mm for all. You'll fine tune them later

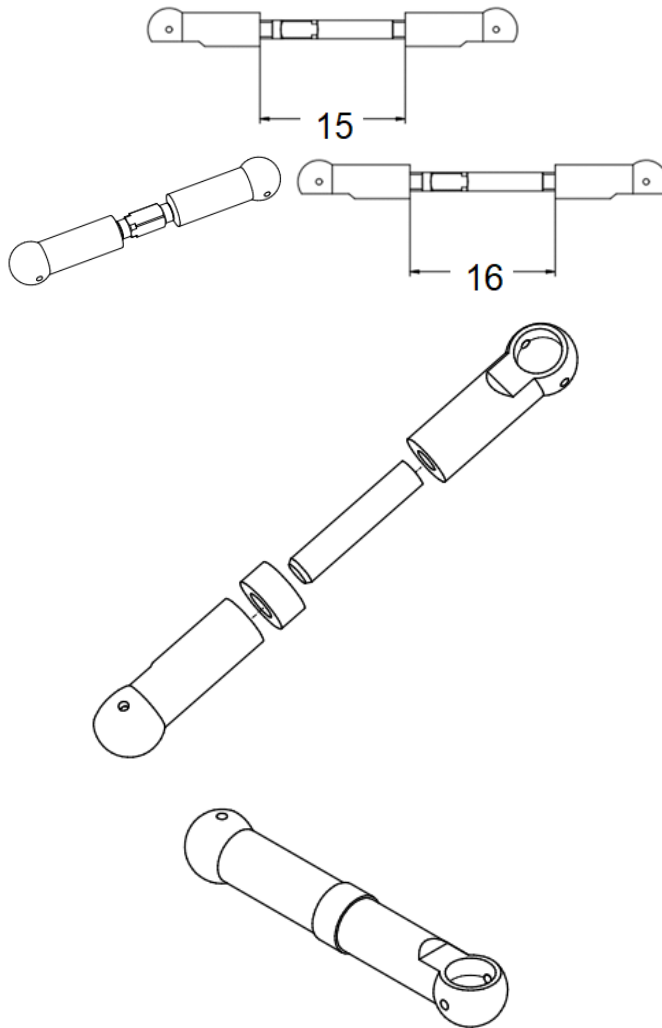

But you can install them now..

Now make a set of 2 tie rods, for the rear toe

16mm for them, again... fine tune later.
Let's prepare the rear pushrods.

Insert an M3x15 grub screw, for about 6mm into the ball joint.

Then slide an 3mm shim and insert another ball joint.

Take care that the ball joint should be oriented 90° between them

Note:

Ground clearance can be altered by changing the length of the pushrods.

Shims are the most easy way to achieve this.

Sway bar aka Anti Roll Bar.

This sway bar system is a bit different from the usual wire bars. You can fix them with 4 by M2.5 x 8 screws.

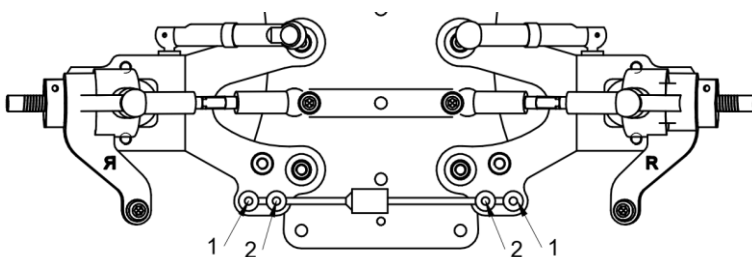

Note:

You can alter the behaviour of the sway bar using more/less screws. For instance, if you fix the sway bars with just screw 1 (instead of 1+2) , the sway bar will be a bit softer.